

STUDY OF THE BRITTLE-ELASTIC MATRIX AND DEFORMATIONS IN THE STRUTS

<https://doi.org/10.5281/zenodo.10775226>

Saparov B. *assistant, Rakhimov M. PhD, senior lecturer,*
Mamatqulova D. *S301-20 TMJ student, Sangirov A. senior lecturer*
Tashkent Institute of Chemical Technology
Yangier branch of the Tashkent Institute of Chemical Technology

Abstract: *In the considered limit problems, the work done between brittle-elastic matrices and stiffeners, the study of the propagation regions and limits of plastic stresses and deformation-degradation are widely used.*

Key words: *Matrix, rod, inclusions, plastic zone, edge effects, stress, deformation, crack*

INTRODUCTION

The influence of edge effects that occur when pipes and pipelines of finite length are immersed in another medium - into rock - is considered. It is assumed that one end or both ends of a pipe or pipeline having a relatively finite length is immersed in some foreign medium in the well, and boundary value problems about the current stressed state of pipes, pipelines and rods are considered.

According to the fundamentals of strength, the theory of elasticity and elastic-plasticity, the decline in the fracture strength of a pipe or pipeline begins from the moment plastic stresses and residual deformations arise in them. Therefore, in all the considered boundary value problems about the joint work of the matrix rock and the inclusion pipe, the regions and boundaries of the propagation of plastic stresses and deformation are studied. It is believed that the operation of pipelines beyond elastic deformations is not permissible [1].

Object of study: The influence of edge effects that occur when pipes and pipelines of finite length are immersed in rock was studied. In the case of brittle components, instead of the plastic zones discussed above, the following local cracks usually appear, which are discussed below in the work.

Relevance: The study of cracks in brittle inclusions and matrices is relevant in the drilling, textile and chemical industries.

Result: In the considered boundary value problems about the joint work of brittle matrices and inclusions, the areas and boundaries of the propagation of plastic stresses and deformations, cracks are explored. It is assumed that there are no relative movements of the inclusion in the matrix.

In the case of brittle components, local cracks appear instead of plastic zones.

In this formulation, the following three boundary value problems are solved:

- brittle rod and elastic matrix: a circular crack of a normal rupture cuts the rod in its middle;
- elastic rod and brittle matrix: a cylindrical longitudinal shear crack (sliding crack) develops along the interface between the medium at the ends of the rod;
- fragile rod and matrix: combination of cases 1° and 2°.

In the case of brittle components, instead of the plastic zones discussed above, the following local cracks of three types usually occur:

1°. *Brittle rod and elastic matrix* : a circular normal fracture crack cuts the rod in its middle (Fig. 1).

2°. *Elastic rod and brittle matrix* : a cylindrical longitudinal shear crack (sliding crack) develops along the interface at the ends of the rod (Fig. 2).

3°. *Brittle rod and matrix* : combination of cases 1° and 2° (Fig. 3).

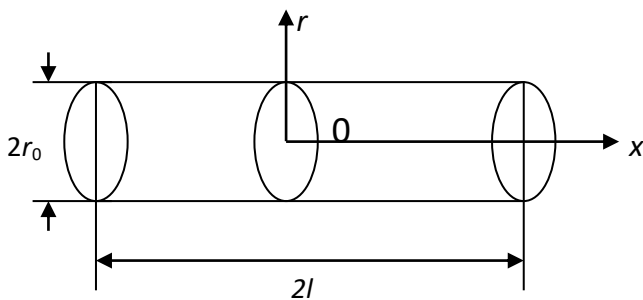

Fig.1

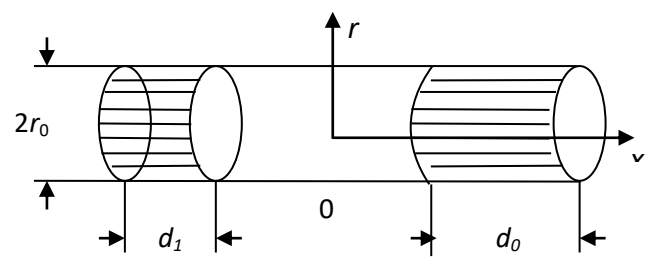

Fig. 2.

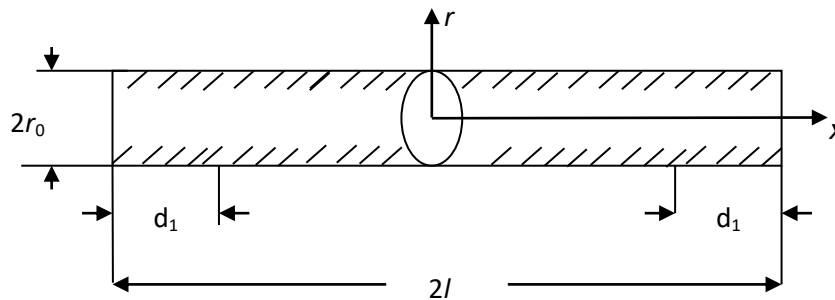

Fig. 3.

Let's consider all these options in order.

1. *Brittle rod and elastic matrix* . In this case, the rod breaks in half as soon as σ_{max} reaches a value σ_{in} , where σ_b is the temporary resistance of the rod to breaking. Using [2], we find the critical value of temperature T_{at} which the inclusion breaks

$$T_e = - \frac{\sigma_b}{a_0 E_f \left(1 - \frac{1}{chk} \right)} \quad (1)$$

Thus, the operating temperature of the material also determines the limit of possible lengths of brittle rods in the matrix.

2. *Elastic rod and fragile matrix*. In this case, the formation of local cylindrical cracks near the ends of the rod occurs as soon as the shear stress τ_{max} reaches a value τ_{in} , where

in τ_s the shear resistance of the matrix or the contact of the matrix with the rod. Using [3], we find for this case the critical temperature T'_e at which cylindrical shear cracks form

$$T'_e = -\frac{2l\tau_s}{r_0 a_0 E_f k t h k}. \quad (2)$$

The further development of a cylindrical crack is determined by methods of brittle fracture mechanics.

Let us consider the problem of determining the development of a cylindrical crack using the theory of invariant integrals.

The specificity of such problems is that on the contour of a cylindrical longitudinal shear crack in the boundary layer approximation there are no features of stresses and strains that should arise when solving problems in an exact formulation. The stress τ_{rx} at the crack front has only a limited maximum, and not a singularity. Therefore, the application of the Griffiths-Irwin theory in this case is impossible due to the absence of a singularity at the crack front [6].

Let us consider some small neighborhood of the crack front, which in cross section is depicted by point O in (Fig. 4). Let us embrace the front with a torus of radius ε (ε -torus), and $\varepsilon \ll r_0$. In this case, the crack can be considered a semi-infinite mathematical cut along $x_2 = 0, x_1 \geq 0$, free from external loads. The x_1 axis runs along the interface between the matrix and the inclusion, along which the crack develops.

Let us denote by S_ε the circular contour $x_1^2 + x_2^2 = \varepsilon^2$ plus the edges of the crack $x = \pm 0, \varepsilon > x > 0$.

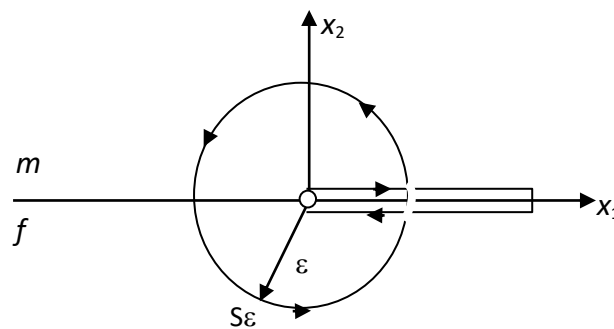

Fig 4.

It is known from theory [6] that the invariant *contour* integral

$$\Gamma = \oint (U n_i - \sigma_{ij} u_i n_j) dS_\varepsilon, \quad i=1, 2 \quad (3)$$

equal to $-\Gamma c$ during crack development. Here u_i – components of the displacement vector σ_{ij} – components of the stress tensor, n_i – components of the unit vector normal to the integration contour S_ε , U – elastic potential per unit volume, Γc – a certain constant of adhesion between a brittle matrix and a brittle inclusion, determined experimentally.

Knowledge of the existence of this structure is sufficient for the successful application of the invariant integral in this case.

Consider a closed surface S formed from the following surfaces:

$$S_{cyl}: r = r_* + 0, |x_1| \leq x_0; S_{bot}: x_1 = \pm x_0, r < r_*;$$

$$S_{cr}: r = r_0 \pm 0, \frac{1}{2}x_0 \geq x \geq 0; S = S_0 + S_{cr} + S_\varepsilon + S_{cyl} + S_{bot}, \quad (4)$$

where x_0 is a certain length, much greater than r_0 , but much less than l and d (Fig. 5).

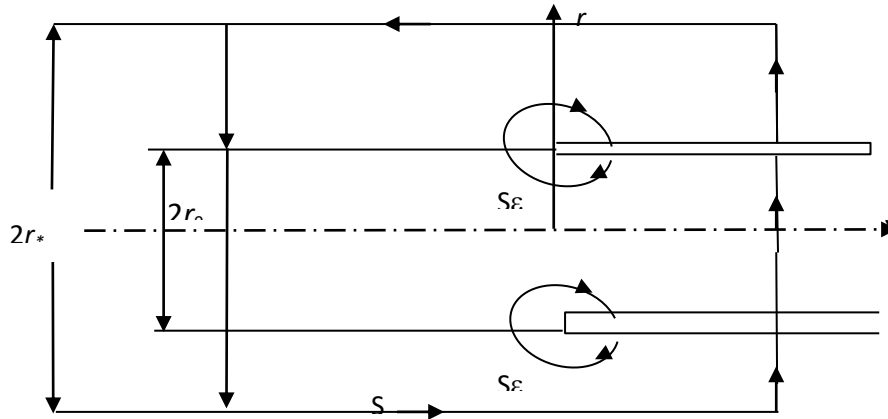

Fig. 5

From the theory of invariant integrals it is known that

$$\int_S \dots = \int_{S_{cyl}} \dots + \int_{S_{cr}} \dots + \int_{S_\varepsilon} \dots + \int_{S_{bot}} \dots = 0, \quad (5)$$

where the dots indicate the integrand expression of the integral (3) with substitution of indices: $1 \rightarrow x, 2 \rightarrow r$.

For the free edges of the crack we find

$$\int_S \dots = 0. \quad (6)$$

Since in the problem under consideration with thermal stresses, stresses and strains outside the boundary layer are equal to zero [6], then

$$\int_{S_{cyl}} \dots = 0. \quad (7)$$

Stress field in the boundary layer $r < r_*, l > x > l - d$ (see Fig. 4) will be as follows

$$\sigma = 0, \quad \tau = 0, \quad W = a_0 T x + C_0, \quad (8)$$

where C_0 is some constant.

Therefore, the integral over the rear end of the cylinder $x_1 = +x_0$ is equal to zero, and over the front end $x_1 = -x_0$ it is equal to

$$\int_{S_{bot}} \dots = \int_{x=-x_0}^{x=0} U dS = 2\pi \int_{r_0}^{r_*} r U dr. \quad (9)$$

Here the following boundary condition for the rod is used

$$\sigma = 0 \text{ at } x_1 = 0,$$

and also the fact that $x_0 \ll l$, therefore the asymptotic field in the rod at $x_1 = -x_0$ is negligible.

In the boundary layer matrix for $x_1 = -x_0$ we have: $n_x = 1, n_r = 0, u_x \neq 0, u_r = 0, \sigma_x = \tau_r = 0, \tau_{xr} \neq 0$, in addition, according to [2] we have

$$U = \frac{1}{2G} \tau_{xr}^2 = \frac{\tau^2 r_0^2}{2Gr^2}. \quad (10)$$

Here the value τ is equal to its maximum value τ_{max} , which is achieved when approaching the crack front in the boundary layer from the left (at the crack front at $x_1 = 0$, the value τ in the boundary layer approximation experiences a discontinuity of the first kind: a jump from τ_{max} at $x_1 = -0$ to zero at $x_1 = +0$).

Based on (3)-(9) we obtain

$$\Gamma = \frac{\tau_{max}^2 r_0}{2G} \ln \frac{r_*}{r_0}. \quad (\text{eleven})$$

This is the density of *the G* integral at the crack front.

Crack development occurs at $\Gamma = \Gamma_c$; the value τ_{max} at the crack front in the boundary layer approximation will be denoted by τ_{With} .

Consequently, when the crack moves, $\tau_{max} = \tau_c, \Gamma = \Gamma_c$. Since the fundamental constant Γ_c is determined in an independent experiment, the constant τ_c of a given problem according to [3] is determined by the following formula

$$\tau_c = \sqrt{\frac{2G\Gamma_c}{r_0 \ln \frac{r_*}{r_0}}}. \quad (12)$$

Let us now return to the problem shown in Fig. 2 about brittle shear cracks at the ends of inclusions; Let's determine their length d using the following boundary condition

$$|\tau| = \tau_c \quad \text{at } x = \pm(l-d), \quad (13)$$

where τ_c is given by the previous equation.

According to [2-3] at $|x| \leq l-d$ we have

$$\sigma = a_0 E_f T \left(\frac{1}{chk} \frac{kx}{l-d} - 1 \right), \quad (14)$$

$$\tau = -\frac{r_0 \alpha_0 E_f T k}{2(l-d)chk} sh \frac{kx}{l-d}, \quad (15)$$

$$W = \frac{\alpha_0 T (l-d)}{kchk} sh \frac{kx}{l-d}, \quad (16)$$

$$\text{Where } K^2 = \frac{2G_m (l-d)^2}{r_0^2 E_f \ln \frac{r_*}{r_0}}. \quad (17)$$

Using (13) and (14) we find

$$thk = \frac{\tau_c}{a_0 E_f T} \sqrt{\frac{2E_f}{G_m} \ln \frac{r_*}{r_0}}. \quad (18)$$

Based on (14) - (18) we obtain

$$d = l - r_0 \sqrt{\frac{E_f}{2G_m} \ln \frac{r_*}{r_0}} \operatorname{arth} \left[\frac{\tau_c}{a_0 E_f T} \sqrt{\frac{2E_f}{G_m} \ln \frac{r_*}{r_0}} \right] \quad (19)$$

If $\tau_{in} > \tau_c$, then after formation the crack abruptly takes on length d according to (19). If $\tau_b = \tau_c$, then the crack length d is a monotonic function of temperature increasing from zero. The dependence of crack length on temperature is shown in Fig. 6 in the following dimensionless variables

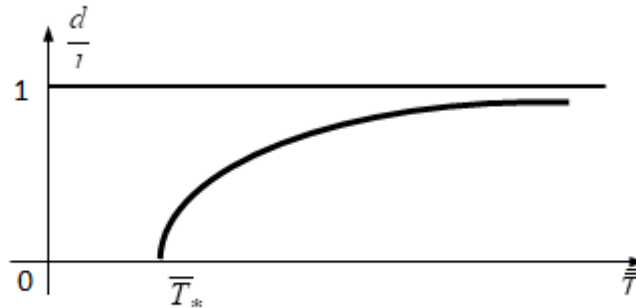

Fig. 6.

$$\bar{d} = \frac{d}{l}, \quad \bar{T} = \frac{a_0 E_f T}{\tau_c}$$

3. The general case of the presence of a non-propagating normal fracture crack in the center of the rod and the formation of two shear cracks at its ends is shown in Fig. 3. In this case, the problem is symmetrical about the vertical axis r . Therefore, we will limit ourselves to considering the part of the rod to the right of this axis. For the right half of the rod we have the following boundary conditions

$$\sigma = 0 \text{ at } x = 0, \quad \sigma = 0 \text{ at } x = l - d, \quad (20)$$

$$\tau = \tau_s \text{ at } x = l - d. \quad (21)$$

The solution to the differential equation [2], satisfying the boundary conditions (20)-(21), has the form

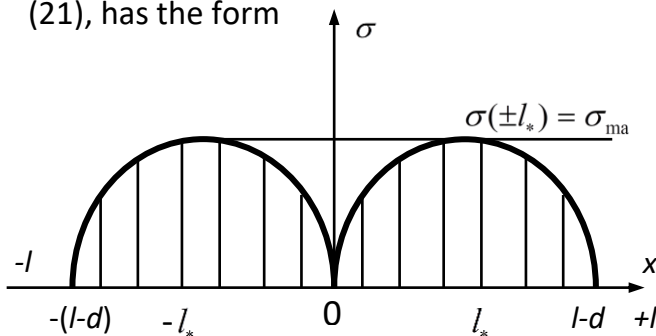

Fig. 7.

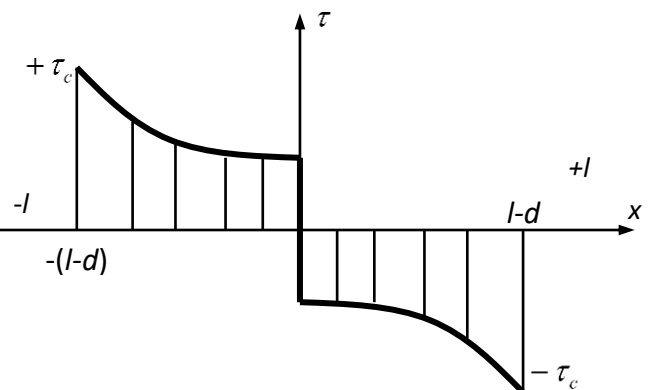

Fig. 8.

$$\sigma = a_0 E_f T \left(-1 + ch \frac{2kx}{l-d} + \frac{1 - ch2k}{sh2k} sh \frac{2kx}{l-d} \right), \quad (22)$$

$$\text{Where} \quad K^2 = \frac{G_m(l-d)^2}{2r_0^2 E_f \ln \frac{r_*}{r_0}} \quad (23)$$

Hence, according to [3] we have

$$\tau = -a_0 E_f T \frac{2kr_0}{l-d} \left(sh \frac{2kx}{l-d} + \frac{1-ch2k}{sh2k} sh \frac{2kx}{l-d} \right). \quad (24)$$

Based on (20)-(21) and (24) we find

$$a_0 E_f T \left(sh2k + \frac{1-ch2k}{sh2k} ch2k \right) = \frac{l-d}{kr_0} \tau_c = \tau_c \sqrt{\frac{2E_f}{G_m} \ln \frac{r_*}{r_0}}. \quad (25)$$

Let's transform this equation to the form

$$thk = \frac{\tau_c}{a_0 E_f T} \sqrt{\frac{2E_f}{G_m} \ln \frac{r_*}{r_0}}. \quad (26)$$

This equation coincides with (18). Consequently, the length of the shear cracks at the ends of the inclusion in the matrix is the same both for the whole rod and for the rod torn in the middle. Stress diagrams σ and τ in the general case, 3° are shown in Fig. 7 and 8.

Normal stresses in the sections $x=0$ and $x=\pm(l-d)$ the rod are equal to zero. Maximum normal stresses occur in the sections $x=\pm l_*$ of the rod (Fig. 7). Tangential stresses in sections $x=0$ also $x=\pm(l-d)$ suffer ruptures. Maximum tangential stresses arise in the sections $x=\pm(l-d)$

CONCLUSION

- brittle rod and elastic matrix: a circular crack of a normal rupture cuts the rod in its middle;
- elastic rod and brittle matrix: a cylindrical longitudinal shear crack (sliding crack) develops along the interface between the medium at the ends of the rod;
- fragile rod and matrix: combination of cases 1° and 2°.

Qualitative and quantitative assessments of VAT are given for fragile inclusions and matrices.

REFERENCES:

- [1]. M.T.Matkarimov, M.Ergashev, J.S.Tavbaev. Strength of flexible elements and pipelines of drilling machines. Bishkek. Ilim 2001. 251 p.
- [2]. Tavbaev J. About cylindrical channel in thick layer. Fergana. The Research journal. 2004 s. 82.
- [3]. Mamasaidov M.T., Ergashov M., Tavbaev J. Toughness flexible element and pipe line drill installation. Bishkek. Ilim. 2001. 251 s.
- [4]. Ergashov M., Tavbaev J. Toughness pipe line drill of the installation. Tashkent. Fan. 2002. 119 s.
- [5]. Tavbaev J, Usmanov H., Tavbaeva D. Drawn near analytical decision of the marginal problem for packed by sloya. //__// Research journal FERPI. 2006. 4 s.5-6.
- [6]. Movlonov T., Tavbaev J., Holikulov E. Determination destroying energy cylindrical bodies.// PROBLEMY TEXTILES .2002. 1.s.76-80.