

**ENSURING SAFE MOVEMENT BY DESIGNING THE OPERATING MODE OF DRIVERS  
WITH THE HELP OF A CAR KEY IN THE ORGANIZATION OF INTERNATIONAL TRANSPORT.**

<https://doi.org/10.5281/zenodo.10929801>

**Nurullo Ikromov**

Doctor of scientist of the Department of " On land transportation systems " Andijan  
machine building institute

**Saidolim Zingirov**

Senior lecturer of the Department of " On land transportation systems ", Andijan  
machine building institute Uzbekistan;

**Oyjamol Mamasoliyeva**

17th school mathematics teacher of Andijan region.

*Annontesion: The drivers 'activities followed their rest regimes The program is developed and put into the system and the car lock The result was committed through the fault of the drivers the number of accidents is reduced several times.*

**Keywords.** *work mode, rest mode, car, car lock, key.*

## **INTRODUCTION**

Due to the fault of ethylgane producers, an accident occurred, as a result of which most of the labor and time spent by the regime on ethylgane production was wasted. The projected Transport and Construction Company has established a basic work and rest regime in accordance with the instructions. As a result, haidovci khokhlagan has a Car time, known only as kalitga, and a time based on the car's operating manual, as a result, the autohalocatlar has many of the same dimensions. He was one of the most respected and respected people in the world[1,2,3,4,5].

## **MATERIAL AND METHODS**

Organization of driver labor activity the purpose of making it is to create normal conditions for drivers, to make it work normally and to ensure that this graph is performed aftomatically with the development of a rest mode. We are now aware that 20-30 percent of autochthonous accidents occur due to the fact that non-observance of this regime occurs. This method has become widespread in the organization of the process of transportation of the driver through the taxograph in international transportation of this issue in Europe and Rassi through the same tool, the operation of the driver and the control of the recreation regime is organized on the basis of tight cracks[6,7,8,9,10]. But even in this style, the elimination of violation of the rule is largely attributed to the driver. If those who commit a violation are fined.

This issue is solved by developing a system program for drivers with a different approach, which is guided on its basis, when the participants of the system insert a key in

the drivers as a system element into it, and the driver's operation and Rest Mode Online are placed in the system[11,12,13,14,15]. The system elements are automatically controlled from the central point of view, counting the elements of a programmable supply of the car ride lever and the starting Switch. When the program-based Automatic Control System Command is received, they are based on the instruction, the system will start if the lock and key coincide the car is designed[16].

## RESULTS

Coming to the elements in the command with the passage of the walk Meyer will not open the lock without matching the lock and key. As a result, the vehicle will be subject to voluntary mandatory height to the command under the regime. We will bring information to lock IGA and key to drive a car with information through the Oline system by developing an efficient program for them to run this system. The car will continue to work when the elements of the code overlap. This situation is guided by the graphics of operation and recreation of drivers in Figure 1. In this process, the process is largely completely controlled, from a small rest of the driver to a large rest[17,18,19,20,21]. Even if the driver wants to work more, the system does not allow him. In doing so, it depends on the approved graph that controls the driver's activity, the 1 and 2 shifts, and how to place this in the system memory via OnLine.

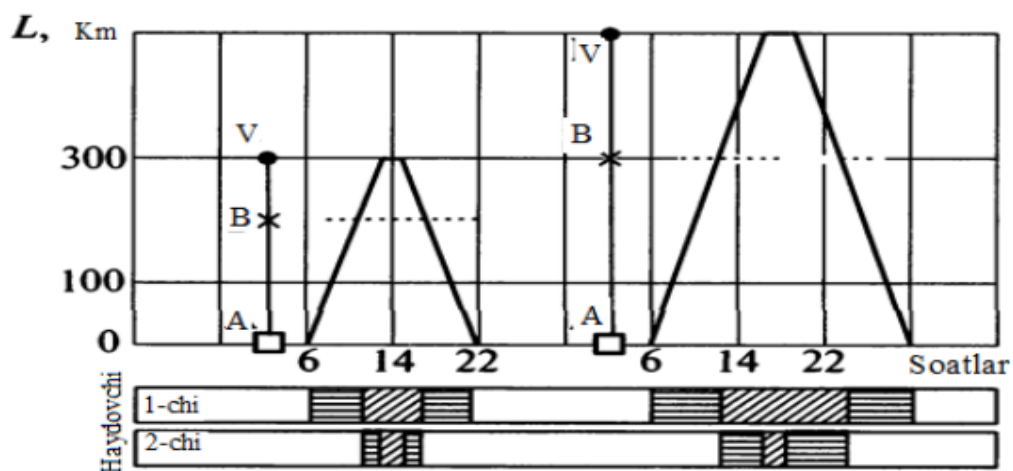

Figure 1. Graph of the mode of entry of drivers for different distances, on a slot or service, work and rest.

In order to organize drivers on the basis of the performance graph of the driver in the presence of different distances, in the accommodation or service, work and rest, in the places of exchange of drivers, a graph is developed. When working the graph, the main emphasis is on the new-old of the car, the graph is viable, which is compiled based on indicators such as the current of the host on the shift Number column, and the host driver is effective to ensure the safety of the character[22,23,24,25]. The main test is to have high results by correctly composing and inserting a graph into use. This is an application for structured graphics drivers. When drawing up a graph, a great emphasis is placed on the driver to rest and follow the mode of operation, as a result of which the previous graphs

and the taxograph in Europe differ from the method in that it consists of making an effective graph for the process and adhering yogurt to it. In the daily activity, the mode is executed, if there is an error, the key in the system through OnLine is automatically excluded from opening the lock. As a result, the driver is replaced by the 2nd driver, who works through the effect of the performance and rest graph.

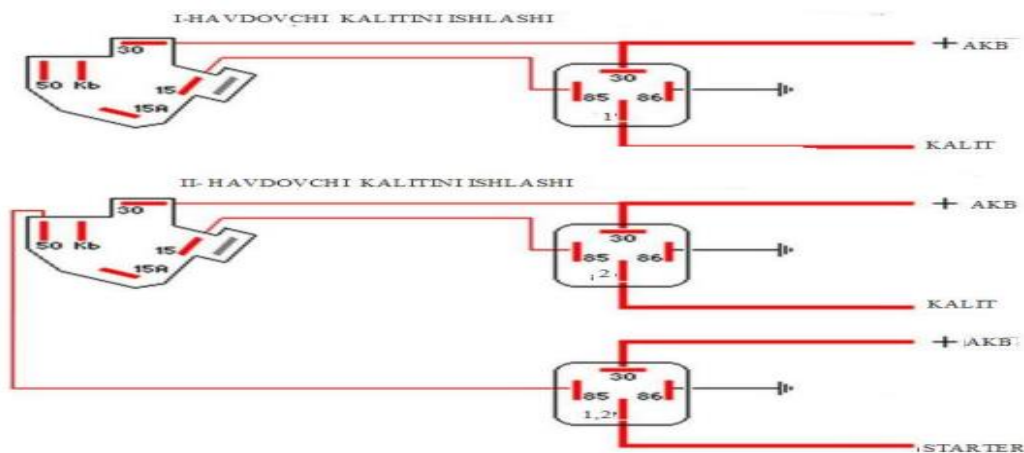

Figure 2. Opening and closing of the car lock

## DISCUSSION

When carrying out this work, information is received through the online system to the reference security zone. This arrangement is achieved by opening and closing the car lock in Figure 2 through the drive shaft. The main task for the car is the graph of the driver's performance and rest with a hold, it is to give the driver a break in the regime and have a reduction in auto accidents. To do this, work the driver and develop a recreation chart plan out[26,27,27,28,29]. This is a car based on a plan of performance and Recreation graph ruined. The result is a plan-based system with Mode Capture destruction is carried out, without opening a car slave in opposite points walking stops, from driving on fatigue points that interfere with the car will be destroyed[30]. Online launch of a cross-country car with pickaxe it was confirmed to him when he went to work and rest the studied driver the acquisition plan is connected via the online store not stated in the graph car ignition system is the second to have a legal rest without opening lock opens to the driver. Thus all cars in transportation the budget is provided according to the plan of the plot of work and Recreation[31,32,33,34,35].

## CONCLUSION

Legal work process of drivers in a car online system the electron is taken into control in the field. The introduction of this system gives the following evolutions:

- plan a car dealership plan to work and relax through it will be dressing the possibility of making quick changes through the system;
- putting drivers into working balance clock mode, putting the tired does not work;

➤ Car will not be put in excess traffic jams, the line is based on the mode bottling with the necessary cars will have to delimit cars that are illicit;

#### REFERENCES:

- [1] Jean-Paul Rodrigue "The Geography of Transport Systems" New York: Routledge, 11309-171 паGES.2016 ISBN 978-0-415-82254-1. 284 паGES
- [2] Зингиров, А. С. (2015). Методика оценки энергоёмкости кормоизмельчительной машины. *Аграрная наука*, (2), 28-29.
- [3] Dostonbek, Z., & Bunyodbek, M. (2022). Examination of Vehicles Carrying Fast-Breaking Cargo. *Eurasian Research Bulletin*, 14, 25-29.
- [4] Mamasoliyev B., Yuldashev X., Yusupova E. The role of transport logistics in management of product supply chains //INTERNATIONAL JOURNAL OF DISCOURSE ON INNOVATION, INTEGRATION AND EDUCATION. – 2021. – Т. 2. – №. 2. – С. 241-243.
- [5] .Икромов Н.А., Гиясидинов А.Ш., Рузиматов Б.Р. Меры по снижению экологического воздействия автопарка // *Universum: технические науки : электрон. научн. журн.* 2021. 4(85). URL: <https://7universum.com/ru/tech/archive/item/11610> (дата обращения: 24.04.2021)
- [6] Mamasoliyev, B., Ismoilov, S., Abdusattarov, N., Arabboyev, R., & Boqiyev, O. (2022). ELIMINATION OF NOISY OPERATION OF DAMAS REAR SUSPENSIONS. *Science and innovation in the education system*, 1(4), 59-63.
- [7] Bunyodbek Mamasoliyev, Abdurahimjon Alijonov, Ergashoy Yusupova. (2020). Development Of A Logistic Method In The Placement Of Urban Passenger Transport Routes. *The American Journal of Social Science and Education Innovations*, <https://www.usajournalshub.com/index.php/tajssei> 2(11), 378-383.
- [8] Мамасолиев Б.М., Косимов М.М., Абдусаттаров Н.Х. Технология производства стальных колес автомобилей и недостатки в их производстве // *Universum: технические науки : электрон. научн. журн.* 2021. 3(84). URL: <https://7universum.com/ru/tech/archive/item/11401> (дата обращения: 25.03.2021)
- [9] Muqimova, D. K., Zingirov, S. J., Axmatohunov, B. M., Zokirov, D. Z., Melikuziev, A. R., & Tursunboev, L. E. (2024, October). The impact of the disc roller's diameter on the combined machine's performance during the sequential processing of freshly planted soil. In *E3S Web of Conferences* (Vol. 471, p. 04013).
- [10] Mamasoliyev B., Abdusattarov N. EFFICIENT MOVEMENT FOR CARGO TRANSPORTATION DETERMINATION OF CONTENT // *Universum: технические науки : электрон. научн. журн.* 2022. 2(95). URL: <https://7universum.com/ru/tech/archive/item/13149>
- [11] Мамасолиев, Б., & Зокиров, Д. (2023). ПАХТА НОВДАСИНИ ОЛИБ ТАШЛАШ УЧУН ТАВСИЯ ЭТИЛГАН ҚУРИЛМАНИ ПАРАМЕТРЛАРИНИ АСОСЛАШ. *Новости образования: исследование в XXI веке*, 1(11), 823-827.

- [12] Taxirjanovich, I. S., & Jo'rayevich, Z. S. (2023). AVTOMOBILLARNING TORMOZLANISH XUSUSIYATLARINI NAZARIY VA EKSPERIMENTAL TADQIQOTLASH. Mexatronika va robototexnika: muammolar va rivojlantirish istiqbollari, 1(1), 268-271.
- [13] Mahammadjonov, N., Mamasoliyev, B., & Muxtorov, S. (2022). CALCULATION OF A ROAD MILLING TOOTH BY THE METHOD OF FINITE ELEMENTS. Current approaches and new research in modern sciences, 1(5), 7-13.
- [14] Ikromov N. FEATURES OF MODERN ELECTRIC CARS //МЕХАНИКА ВА ТЕХНОЛОГИЯ ИЛМИЙ ЖУРНАЛИ. – 2023.
- [15] Muqimova D. et al. LOCATION AND DEVELOPMENT OF THE MAIN NETWORKS OF WORLD TRANSPORT //Theoretical aspects in the formation of pedagogical sciences. – 2022. – Т. 1. – №. 4. – С. 279-284.
- [16] Мамасолиев, Б. М. У., Угли, Қ. М. М., & Абдусаттаров, Н. Х. (2021). Технология производства стальных колес автомобилей и недостатки в их производстве. Universum: технические науки, (3-1 (84)), 58-61.
- [17] Mamasoliyev, B., Melikuziev, A., & Sotvoldiyev, O. (2022). Research of Factors Affecting the Cylinder-Porshen Group Work Process. Texas Journal of Engineering and Technology, 7, 8-12.
- [18] Bakirov, L., Mamasoliyev, B., Usmonov, U., Ismailov, S., & Muxtorov, R. Z. (2022). GUARANTEE SAFE MOVEMENT BY DESIGNING DRIVER'S WORK MODE THROUGH VEHICLE KEY IN ORGANIZING INTERNATIONAL TRANSPORTATION. International Bulletin of Applied Science and Technology, 2(10), 154-158.
- [19] Mamasoliyev B., Yuldashev X., Yusupova E. The role of transport logistics in management of product supply chains //INTERNATIONAL JOURNAL OF DISCOURSE ON INNOVATION, INTEGRATION AND EDUCATION. – 2021. – Т. 2. – №. 2. – С. 241-243.
- [20] Bakirov, L. Y., Ziyamukhamedova, U. A., Mamasoliev, B., & Mahammadjonov, N. (2022). RESEARCH OF PHYSICAL AND MECHANICAL PROPERTIES OF HETEROCOMPOSITE POLYMER MATERIALS AND COATINGS FORMED FROM THEM HELIOTECHNOLOGICAL METHOD. Theoretical aspects in the formation of pedagogical sciences, 1(6), 224-230.
- [21] Икромов, Н. А. Гиясидинов Абдуманоб Шарохинович, & Рузиматов Бахром Рахмонжон Угли (2021). МЕРЫ ПО СНИЖЕНИЮ ЭКОЛОГИЧЕСКОГО ВОЗДЕЙСТВИЯ АВТОПАРКА. Universum: технические науки,(4-1 (85)), 44-47.
- [22] Ikromov N. INVESTIGATION OF THE EFFECT OF MAGNETIC TREATMENT OF POLYMER COATINGS ON THEIR ADHESIVE AND PHYSICAL AND MECHANICAL PROPERTIES //МАШИНАСОЗЛИК ИЛМИЙ-ТЕХНИКА ЖУРНАЛИ. – 2022.
- [23] 17. Ikromov N. et al. KRISTALLANISH VA QOTISHMALARNING QOTISH JARAYONIDA KOMPONENTLARNING O 'ZARO TA'SIRI //Theoretical aspects in the formation of pedagogical sciences. – 2022. – Т. 1. – №. 6. – С. 39-46.
- [24] 18. Негматов С.С. и др. Исследование антифрикционно-виброзвукопоглощающих композиционных полимерных материалов и покрытий на их основе //Universum: технические науки. – 2021. – №. 8-1 (89). – С. 11-15.

- [25] 19. Ikromov N.A. et al. SHAHAR KO 'SHALARIDA TRANSPORT VOSITALARINING HARAKAT JADALLIGINI O 'RGANISH //Новости образования: исследование в XXI веке. – 2022. – Т. 1. – №. 5. – С. 863-872.
- [26] 20. Икромов Н. Физическая модификация термопластичного полимерного композиционного материала: дис. – Белорусско-Российский университет, 2019.
- [27] 21. Давлатов Р. М. и др. Разработка полимерной композиции для улучшения свойств шерсти //Все материалы. Энциклопедический справочник. – 2017. – №. 8. – С. 13-18.
- [28] 22. Avazbekovich I. N. Transport vositalarning texnik holatini baholash //World scientific research journal. – 2023. – Т. 18. – №. 1. – С. 92-97.
- [29] 23. Икромов Н. и др. ОПРЕДЕЛЕНИЯ ФИЗИКО-МЕХАНИЧЕСКОЕ ПРОЧНОСТЬ ПОЛИМЕРНЫХ ПОКРЫТИЙ ОБРАБОТАННЫХ В МАГНИТНОМ ПОЛЕ //Science and innovation in the education system. – 2022. – Т. 1. – №. 6. – С. 16-22.
- [30] 24. Негматов С. С. и др. Триботехнические свойства композиционных материалов на основе термопластичного полимера и органоминеральных наполнителей при контактном взаимодействии с волокнистой массой (хлопком-сырцом) //Физика и химия обработки материалов. – 2020. – №. 5. – С. 66-74.
- [31] 25. Avazbekovich I. N., Shoxobiddin ogli T. F., Shuhratbek ogli A. A. REQUIREMENTS FOR THE DESIGN OF AN AUTO PARTS STORE //Лучшие интеллектуальные исследования. – 2023. – Т. 10. – №. 1. – С. 160-163.
- [32] 26. Ikromov N. YENGIL AVTOMOBILLARGA TAKSI SAROYINI LOYIHALSH //Scienceweb academic papers collection. – 2023.
- [33] 27. Avazbekovich I. N. AVTOMOBILLARGA KUNLIK QAROV VA DIAGNOSTIKA ISHLARINI TASHKILLASHTIRISH //Новости образования: исследование в XXI веке. – 2023. – Т. 2. – №. 14. – С. 112-116.
- [34] 28. Ikromov N. KINEMATIC CALCULATION OF THE HYDRAULIC SYSTEM OF THE UNLOADING DEVICE OF TRAILERS //Proceeding X International Conference «Industrial Technologies and Engineering» ICITE–2023, Volume III. – Scienceweb-National database of scientific research of Uzbekistan, 2023.
- [35] Ikromov, N., Alijonov, A., Soliyev, B., Mamajonov, Y., Mahammadjonov, N., & Meliqoziyev, A. (2021). Analysis of mechanical properties of polymer bushing used in automobile industry. Asian Journal of Multidimensional Research (AJMR), 10(3), 560-563.